

## DEVELOPING A FIRE-RISK RELIABILITY MODEL FOR POWER DISTRIBUTION SYSTEMS USING RBI METHODS

*A. M. Affif  
Alan March  
Yulesta Putra*

---

*This study enhances fire-risk identification for power distribution systems by applying risk-based inspection (RBI) principles to develop a reliability-oriented fire-risk model and to translate assessment results into a targeted fire detection plan for the evaluated assets. Fire occurrence probability for distribution lines is characterized through five key parameters, which are mapped to standardized probability levels to determine the likelihood category for each line. Fire consequence severity is described using six parameters and classified according to predefined consequence-level criteria. A fire-risk matrix is then used to integrate likelihood and consequence to evaluate overall fire-risk reliability across the distribution system. In a case study of a specific substation, the proposed RBI-based assessment identified three high-risk items, and corresponding prevention and control measures were recommended to support corrective actions and risk reduction.*

*Index Terms* — RBI, distribution system, risk matrix, reliability model

---

© The author(s) 2025. This article is an open access article distributed under the terms and conditions of the Creative Commons Attribution (CC BY 4.0) license (<http://creativecommons.org/licenses/by/4.0/>).

## INTRODUCTION

With continuous technological progress, the number of electrical devices used in both industrial activities and daily life has increased substantially. Consequently, electricity has gradually become one of the most critical energy sources supporting modern production and everyday living [1, 2]. Although the widespread application of electricity has greatly improved convenience and efficiency, it also introduces significant safety risks. In recent years, electrical fires have represented the largest proportion of fire incidents in China's fire accident statistics. Such fires are mainly attributed to factors including electric leakage, short circuits, and equipment overloading [3, 4, 5]. Regions with a high incidence of electrical fires are predominantly large and medium-sized cities as well as economically developed areas, and the frequency of these accidents has shown a persistent upward trend [6, 7]. Electrical fires often occur in densely populated locations, such as farmers' markets, large shopping malls, cinemas, and other cultural or entertainment facilities [8, 9]. As a result, electrical fire accidents have caused considerable negative impacts on economic development, and the severity of these impacts continues to intensify [10].

In view of the increasingly serious situation of electrical fire incidents, current fire safety efforts emphasize preventive strategies, including accident prediction, early warning, and risk forecasting, with the aim of eliminating potential causes at the source [11, 12, 13, 14]. At present, electrical fire safety inspections remain one of the most effective approaches to reducing the occurrence of such accidents. By identifying hidden hazards and evaluating associated risks, these inspections play a crucial role in preventing fire incidents [15, 16]. Therefore, effective prevention of electrical fires requires strict adherence to the principle of "safety first and prevention as the priority." Reliability-based models should be employed to conduct systematic safety inspections of electrical equipment, allowing potential hazards to be promptly identified and eliminated, thereby reducing the likelihood of electrical fire accidents [17, 18, 19, 20].

To address the growing threat posed by electrical fires, numerous researchers have proposed various inspection and detection techniques. Reference [21] presents a real-time deep learning approach for fault classification and localization in large-scale power distribution networks. By extracting feature vectors from measured distribution line data, the method can not only identify areas with potential fire risks but also accurately distinguish different fault types. Reference [22] develops an intelligent electrical fire detection technique tailored for green buildings, where multi-source information fusion is used to detect arc faults in building distribution systems, and simulation results confirm the reliability of the detection method, effectively reducing fire risks. In [23], intelligent electronic device relays are combined with controllable solid-state circuit breakers to construct a DC fault detection scheme capable of characterizing transient behaviors under different fault conditions and locations, thereby enhancing distribution system protection. Reference [24] introduces a power line communication-based method for real-time identification of fault types and locations. By applying a zero-crossing detector to determine the phase sequence of R, Y, and B phases, accurate fault indication is achieved.

Furthermore, reference [25] investigates detection and isolation strategies for series DC arc faults in distribution systems. An integrated machine learning algorithm is employed to train on multiple arc fault indicators, enabling reliable identification of arc faults under diverse load conditions and effectively mitigating fire hazards. Reference [26] points out that photovoltaic distribution systems under partial shading exhibit similar operational and fault characteristics. By applying wavelet packet analysis to voltage and current signals from photovoltaic arrays, fault detection accuracy is enhanced and protective tripping performance is significantly improved. In addition, reference [27] emphasizes the importance of early modeling and detection of DC arc faults in photovoltaic systems. By comparing arc fault models under different operating conditions, the detection rate of arc faults is improved, thereby reducing the risk of severe fire accidents associated with photovoltaic installations. Although the aforementioned methods contribute to the safe and reliable operation

of distribution systems, they generally overlook inspection workload and associated costs, which may limit overall risk management efficiency. Risk-Based Inspection (RBI) technology addresses this limitation by evaluating both the probability of hazardous events and the severity of their consequences, enabling prioritized, targeted, and scientifically grounded inspection strategies. This approach not only ensures reliable system operation but also enhances safety performance, making it particularly suitable for electrical fire prevention.

In this study, fire risk in distribution systems is systematically evaluated by considering two key dimensions: the likelihood of accident occurrence and the severity of resulting consequences. A reliability model for distribution system fire risk is established, where the probability of a fire accident is calculated using

$$F = (1 - F_1)(1 - F_2)(1 - F_3)(1 - F_4)(1 - F_5),$$

and the severity of accident consequences is determined by

$$C = C_1 + C_2 + C_3 + C_4 + C_5 + C_6.$$

Through case studies, the fire risk reliability of the distribution system is evaluated, and corresponding fire prevention and mitigation measures are proposed.

## **RISK-BASED INSPECTION (RBI) TECHNOLOGY**

Risk-Based Inspection (RBI) is an optimized inspection strategy developed under the principle of balancing system safety and economic efficiency. It is essentially a management approach that seeks to ensure intrinsic system safety while simultaneously reducing operating and maintenance costs. This is achieved through a scientific evaluation of both the likelihood of inherent or potential hazardous events and the severity of their consequences, followed by risk prioritization and the identification of critical weaknesses within the system [28].

### *Basic Principles of RBI*

RBI establishes a direct connection between the risks encountered during equipment operation and in-service inspection activities. By applying systematic risk analysis, all equipment involved in a process, such as pipelines and auxiliary components, is evaluated and ranked according to its associated risk level. Inspection resources are then focused primarily on high-risk equipment, using inspection techniques specifically matched to the relevant damage mechanisms. This targeted approach significantly reduces overall system risk and ensures that, during subsequent operating cycles, the risk level of all equipment remains within acceptable limits.

Inspection plans developed using the RBI methodology generally do not require routine inspections for medium- and low-risk equipment. As a result, RBI represents an advanced inspection planning method that not only mitigates equipment-related risks but also effectively reduces inspection workload and operational costs.

Within the RBI framework, risk is defined as the product of the probability of failure over a given period and the consequences associated with that failure, including potential losses to personnel, the environment, and economic assets. Risk can be expressed as

$$\text{Risk} = \text{Failure Probability} \times \text{Failure Consequence}. \quad (1)$$

From this definition, it follows that risk management can be approached from two complementary perspectives: decreasing the likelihood of failure and minimizing the resulting losses. Recognizing this two-dimensional nature of risk, RBI enables equipment integrity management through more focused and effective risk control measures.

In quantitative RBI analysis, the probability of failure is typically represented as the combined effect of three factors: the general failure frequency (GFF), the equipment correction factor ( $F_E$ ), and the management system evaluation factor ( $F_M$ ). Accordingly, the failure probability is given by

$$\text{Failure Probability} = \text{GFF} \times F_E \times F_M. \quad (2)$$

### *Analytical Approaches in RBI*

RBI systematically identifies potential failure mechanisms and failure modes of all equipment within a system, evaluates both the probability and consequences of failure, and calculates the corresponding risk level for each item. Based on these results, equipment is ranked by risk, allowing inspection efforts to be concentrated on high-risk components. Medium- and low-risk equipment may require reduced inspection frequency or, in some cases, no inspection at all.

RBI analytical methods are generally classified into three categories: qualitative, quantitative, and semi-quantitative. These approaches are not mutually exclusive; rather, they complement one another and together form a continuous and integrated analytical framework. In practice, a typical RBI project often combines all three methods, with the specific choice depending on the objectives and stage of inspection planning.

Qualitative RBI methods rely primarily on engineering judgment and practical experience. They require relatively limited data input and use simplified evaluation techniques to estimate failure likelihood and consequence severity. Although this approach enables rapid and approximate risk ranking, it tends to produce conservative inspection plans and must be implemented by personnel with substantial expertise.

Quantitative RBI methods, by contrast, offer high precision but are more resource-intensive. They involve detailed analysis of large datasets to generate accurate risk rankings for all equipment. These methods can identify instances of excessive or insufficient inspection, optimize inspection intervals for high-risk equipment, and quantify both inspection costs and the economic benefits of RBI implementation.

Semi-quantitative RBI methods represent a compromise between qualitative and quantitative approaches. While they require similar types of data as quantitative methods, they allow for simplified assumptions, such as approximate estimation of process fluid volumes. This significantly reduces analysis time while still capturing most of the insights provided by fully quantitative RBI.

In practical applications, a qualitative or semi-quantitative RBI analysis is often conducted initially for the entire facility, followed by a detailed quantitative analysis focused on equipment located in high-risk areas.

The general workflow of an RBI program is illustrated in Figure 1, which outlines the essential steps of a risk-based inspection plan. These elements are fundamental to any comprehensive RBI implementation, regardless of the specific analytical method employed.

### *Application of RBI Technology in Distribution Systems*

In power distribution systems, the concept of risk management was initially introduced in the nuclear power industry and later extended to other sectors, including thermal power generation. Within thermal power

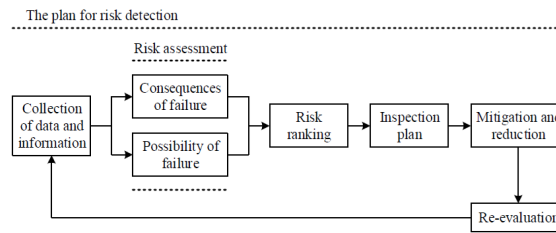

Figure 1: The process of RBI

Figure 1: The process of risk-based inspection (RBI).

plants, risk-based maintenance is commonly implemented through two complementary approaches: risk-based inspection (RBI) and risk-based maintenance (RBM). The typical implementation procedure includes system segmentation, identification of critical components, data preparation, determination of damage mechanisms, identification of high-risk equipment, risk grading, and subsequent risk management.

In recent years, the adoption of risk inspection and risk management strategies in power distribution systems has provided an additional layer of safety assurance for electrical equipment. Looking ahead, integrating RBI with remaining-life assessment within asset integrity management frameworks is expected to further enhance the effectiveness and reliability of distribution system operation [29].

## ESTABLISHMENT OF A RELIABILITY MODEL FOR FIRE RISKS IN POWER DISTRIBUTION SYSTEMS

### *Prerequisites for Model Development*

The fire risk assessment framework for power distribution systems proposed in this study is designed to satisfy the general requirements of fire safety inspections for low-voltage distribution lines, lighting installations, and common low-voltage electrical equipment. The assessment encompasses visual inspections, instrument-based testing, fire hazard identification methods, and procedures for managing inspection outcomes within power distribution systems. To ensure model applicability and analytical clarity, the following assumptions are adopted:

1. The terminal electrical equipment connected to the power distribution system operates reliably and safely.
2. Both primary and secondary power distribution devices are assumed to be reliable and free from inherent safety defects.

### *Fire Risk Reliability Model*

According to the general definition of risk, accident risk is characterized by both the likelihood of occurrence and the severity of its consequences. Risk therefore reflects not only how likely an accident is to occur but also the extent of its potential impact. In this study, fire risk in power distribution systems is expressed as

$$R = F \times C, \quad (3)$$

where  $R$  denotes the risk of an electrical wiring fire accident,  $F$  represents the probability of a fire accident, and  $C$  indicates the severity of the associated consequences. This definition highlights that an accurate evaluation

of risk requires a comprehensive assessment of both probability and consequence dimensions.

### Probability of Fire Accidents

A complete power distribution system can be regarded as a closed loop composed of load terminals (electrical equipment), conductors, switches, circuit breakers, power sources, and related components. The structural configuration of a typical power distribution circuit is illustrated in Figure 2.

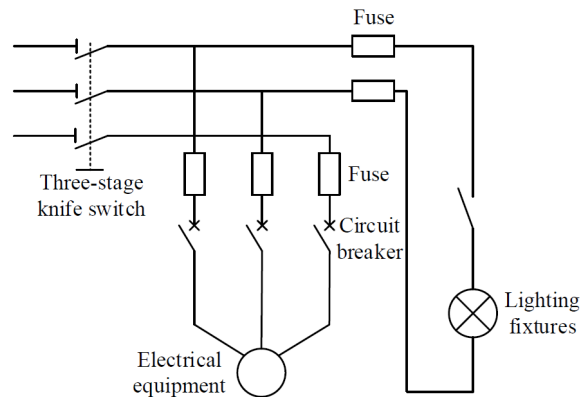

Figure 2: Construction chart of distribution line

From a reliability perspective, all components within the distribution circuit are connected in series. Under normal operating conditions, the system functions correctly only when all components remain operational. Failure of any single component may therefore result in overall system failure.

Based on the assumptions of this study, primary and secondary power distribution equipment are considered reliable and safe. Considering the circuit structure and the mechanisms leading to distribution system fires, a fault tree for fire accidents in power distribution systems can be constructed.

To quantify the probability of fire occurrence, several contributing factors are defined. The load coefficient  $F_1$  is introduced to evaluate the failure rate of electrical equipment, primarily reflecting whether overload conditions exist within the distribution lines:

$$F_1 = P(X_1). \quad (4)$$

The damage coefficient  $F_2$  is used to assess the failure probability of electrical wiring, focusing on physical damage or deterioration of conductors:

$$F_2 = P(X_2). \quad (5)$$

Connection points, commonly referred to as wire terminals, play a critical role in system reliability. Improper installation or poor contact at these points increases electrical resistance, potentially generating localized overheating after energization and triggering fire hazards. To capture this effect, the resistance coefficient  $F_3$  is defined to evaluate whether circuit connections comply with installation standards:

$$F_3 = P(X_3). \quad (6)$$

Certain electrical devices, such as high-temperature heating equipment, rapidly convert electrical energy into heat. When placed near combustible materials, such equipment significantly elevates fire risk. Accordingly,

the equipment coefficient  $F_4$  is used to assess overheating-related risks:

$$F_4 = P(X_4). \quad (7)$$

Combustible materials constitute another critical factor in distribution system fires. These materials are often introduced during installation when components are placed too close to flammable substances. To reflect installation quality and compliance, the process coefficient  $F_5$  is defined as

$$F_5 = P(X_5). \quad (8)$$

By determining the occurrence probabilities of all basic events in the fault tree, the probability of the top event—namely a fire accident in the power distribution system—can be obtained as

$$F = P(T). \quad (9)$$

The overall probability of a fire accident in the distribution system is therefore calculated using the following expression:

$$F = (1 - F_1)(1 - F_2)(1 - F_3)(1 - F_4)(1 - F_5). \quad (10)$$

The classification of failure probability levels is summarized in Table 1.

Table 1: Failure probability level classification

Failure probability coefficient	Feature	Probability level
0–0.2	Rare	1
0.2–0.4	Occasional	2
0.4–0.6	Moderate	3
0.6–0.8	Likely	4
>0.8	Frequent	5

### Consequence Analysis

The severity of fire accident consequences in power distribution lines is influenced by multiple independent factors. In this study, six parameters are used to characterize consequence severity: fire load coefficient  $C_1$ , firefighting capability coefficient  $C_2$ , environmental coefficient  $C_3$ , personnel exposure coefficient  $C_4$ , protection coefficient  $C_5$ , and toxicity coefficient  $C_6$ . Since these factors are mutually independent and their effects are cumulative, the overall consequence severity is calculated using a linear summation:

$$C = C_1 + C_2 + C_3 + C_4 + C_5 + C_6. \quad (11)$$

The classification of consequence severity levels is provided in Table 2.

### Risk Level Classification

Based on the calculated probability and consequence values, the assessed objects are categorized into four distinct risk levels. The corresponding risk matrix is illustrated in Figure 3. During the application of RBI methodology, different management and inspection strategies are adopted for different risk levels, as summarized in Table 3. These levels include low risk, medium risk, medium-high risk, and high risk, enabling targeted inspection, maintenance, and mitigation measures tailored to the specific risk profile of each distribution system component.

Table 2: Consequence severity grading

Damage score	Grade	Severity level
0–20	A	Negligible
21–40	B	Moderate
41–60	C	Severe
61–80	D	Hazardous
>81	E	Catastrophic

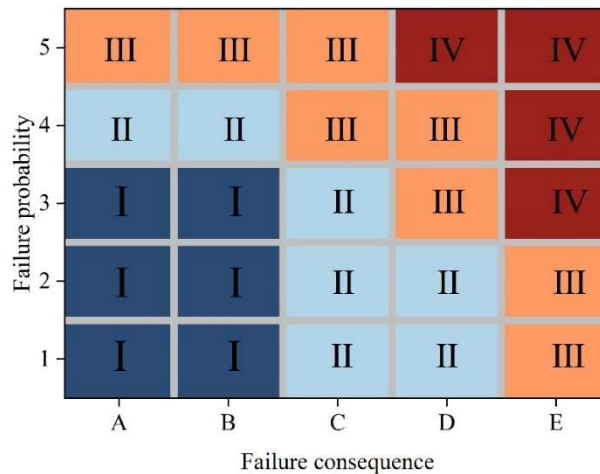

Figure 3: Risk matrix

Table 3: Risk hierarchy and corresponding countermeasures

Grade	Risk level	Countermeasures
I	Low risk	Reduce inspection intensity and extend inspection intervals
II	Medium risk	Perform routine inspection and maintenance
III	Medium-high risk	Implement online monitoring and nondestructive testing; shorten inspection cycles
IV	High risk	Strengthen management, rectify hazards, and eliminate accident risks

## APPLICATION EXAMPLES

### *Overview of the Power Distribution System*

The case study considers a 330 kV unmanned substation with a station area extending 120 m in the east–west direction and 95 m in the north–south direction. The site has an average annual temperature of 15.4°C, with an extreme maximum temperature of 38.5°C, and an average wind speed of 2.5 m/s. The main entrance of the substation is located on the western side. The main control and communication building adopts a linear layout oriented along the north–south axis. Facilities associated with the 330 kV system, including the 330 kV structure, GIS foundation, and relay room, are arranged on the northern side of the station area.

The 110 kV structure, GIS foundation, 330 kV relay room, and the No. 2 35 kV distribution room are located between the 110 kV and 330 kV distribution areas. Capacitor banks and reactors are installed on both sides of the main transformers. The substation is equipped with three 240 MVA main transformers, four 30 MVA oil-immersed capacitors, and four 30 MVA reactors. The outdoor cable trenches are constructed using cast-in-place reinforced concrete with integrated drainage channels at the trench bottom, and the covers consist of prefabricated composite high-strength panels. The main circular fire lane within the station has a

clear width of 4.0 m, a turning radius of 9 m, and a longitudinal slope of 0.5%. This fire lane connects with other internal roads at two locations.

The fire resistance rating of internal structural columns is 2.4 h, while structural beams have a fire resistance rating of 1.4 h. Load-bearing walls are 250 mm thick with a fire resistance rating of 2.4 h, whereas non-load-bearing walls have a thickness of 115 mm and a fire resistance rating of 0.4 h.

The fire control room also functions as the main control room. Fire protection electrical equipment includes a fire alarm control panel supplied by dual power sources, namely an uninterruptible power supply (UPS) and a battery system. Apart from the main control and communication room, no dedicated fire protection electrical equipment is installed in other equipment rooms.

Emergency lighting is designed to provide 10% of normal illuminance. Evacuation signage is installed at exits and along personnel passageways. Emergency lighting loads are supplied by an accident lighting distribution panel equipped with both AC and DC inputs. Under normal operating conditions, AC power is used, while in the event of an AC failure, DC power is converted to AC via an inverter transformer, ensuring a continuous power supply for up to 2 h.

The substation is equipped with an integrated fire alarm system designed to provide early detection and timely warning of fire incidents.

The main transformers are protected by a fixed fire extinguishing system based on oil drainage combined with nitrogen injection. Nitrogen cylinders with a capacity of 45 L are installed, and the oil drainage pipeline has a nominal diameter of DN150. In addition, ammonium phosphate dry powder fire extinguishers of various specifications are deployed in the main transformer area, secondary equipment rooms, monitoring rooms, battery rooms, and other key locations.

### *RBI Risk Assessment*

Based on the defined inspection scope and partitioning of the system, the distribution of equipment and components within each zone is summarized in Table 4.

Following the statistical analysis of equipment data in the four zones, failure probabilities were calculated and corresponding risk levels were determined.

For Zone 1, the risk matrix results are presented in Figure 4. The analysis indicates no high-risk items, one medium–high-risk item, eight medium-risk items, and eight low-risk items. The economizer suspension pipe exhibits relatively elevated risk due to fly ash erosion, and the recommended mitigation measure is enhanced macroscopic inspection during scheduled maintenance periods.

The risk assessment results for Zone 2 are illustrated in Figure 5. One high-risk item, one medium–high-risk item, and four medium-risk items are identified, with the remaining components classified as low risk. The water-cooled wall internal threaded pipe is the highest-risk component, primarily affected by H<sub>2</sub>S corrosion. Process parameter adjustment is considered the most effective control strategy.

Figure 6 presents the analysis results for Zone 3, where two high-risk items, two medium–high-risk items, four medium-risk items, and eleven low-risk items are identified. One high-risk component is the screen inlet pipe, for which high-temperature overheating is the dominant damage mechanism and creep measurement is recommended. The other high-risk component is the screen outlet pipe, mainly affected by spheroidization, requiring metallographic examination and hardness testing.

Table 4: List of projects in each partition

Partition	Item name	Quantity
Zone 1	Coal pipe	1
	Provincial coal holder suspension tube	1
	Provincial coal entry box	3
	Economizer outlet header	2
	Water wall internal thread	1
	Water cooler	5
Zone 2	Upper wall	3
	Water-cooled wall drain	2
	Horizontal flue wall	1
	Upper wall	1
	Ceiling superheater tube	2
	Underpass	3
	Wall tube	5
Zone 3	Screen tube	1
	Screen overboard	3
	End superheater inlet tube	2
	End superheater outlet tube	2
Zone 4	Reheater cold section inlet tube	5
	Reheater cold section outlet pipe	1
	Reheater hot section inlet tube	3
	Reheater hot section outlet pipe	2
	Reheater inlet header	1
	Reheater outlet small header	3
	Reheater outlet catheter	4

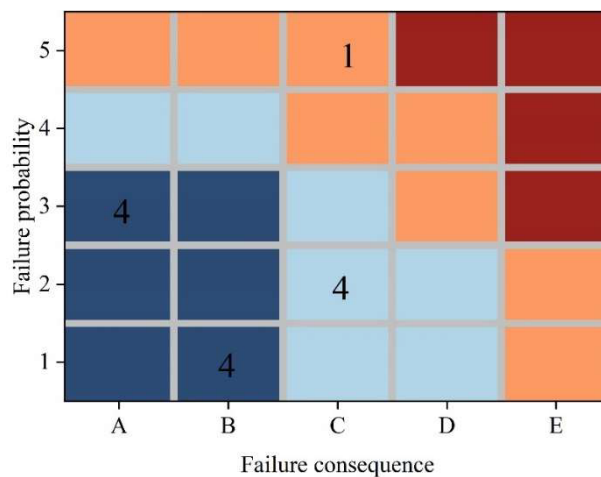

Figure 4: Analysis results of Zone 1

For Zone 4, as shown in Figure 7, no high-risk items are observed. Instead, two medium–high-risk items, four medium-risk items, and two low-risk items are identified. The reheater cold section inlet and hot section outlet are the most critical components, with water–steam erosion identified as the primary damage mechanism. Adjusting the operating mode of the soot blower is proposed as an effective mitigation measure.

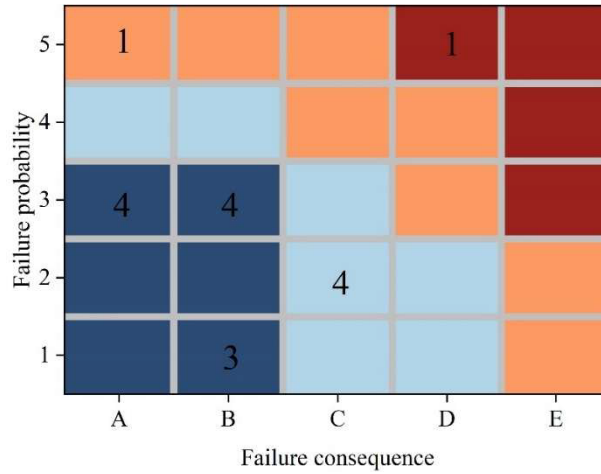

Figure 5: Analysis results of Zone 2

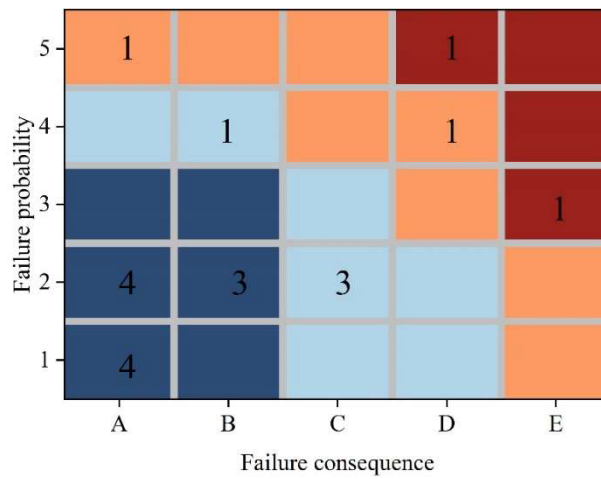

Figure 6: Analysis results of Zone 3

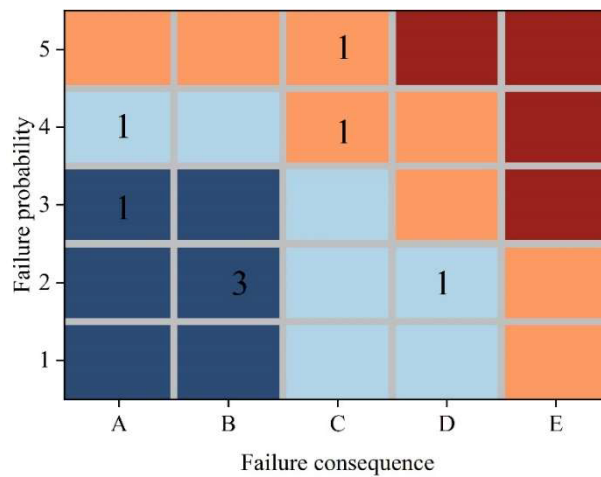

Figure 7: Analysis results of Zone 4

The distribution of equipment across different risk levels in the four zones is summarized in Figure 8. The number of items classified as high, medium-high, medium, and low risk are 3, 6, 14, and 34, respectively. Overall, the fire risk reliability model indicates the presence of three high-risk components in the substation, for which immediate fire prevention and control actions are required.

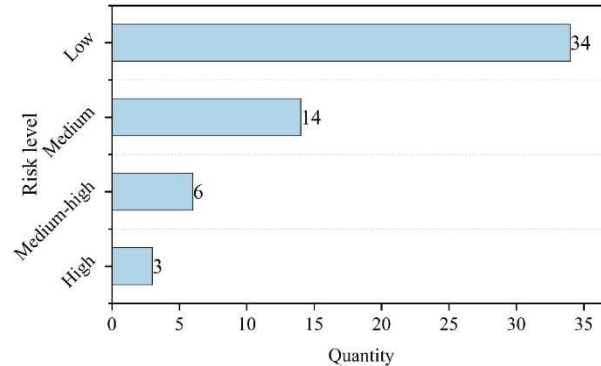

Figure 8: The number of devices at different risk levels in four partitions

#### *Fire Prevention and Control Measures for Power Systems*

Long-term reduction of fire accident occurrence in power systems depends on the implementation of comprehensive fire management strategies. These include the establishment of standardized operating procedures, regular emergency drills, and the application of information technologies to enhance fire safety awareness and emergency response capability. According to the *Fire Prevention Management Regulations for Power Systems*, power enterprises are required to organize no fewer than four fire drills annually, with the frequency doubled during high-risk periods such as summer. Empirical evidence shows that routine drills can shorten emergency response times by more than 20%.

In accordance with the *Electric Power Safety Training Standards*, a minimum of 24 h of mandatory annual training is required to disseminate firefighting knowledge and improve practical skills. Training content covers early fire detection, emergency evacuation procedures, and correct operation of firefighting equipment, ensuring that all personnel possess fundamental response capabilities. Emergency plan formulation and implementation constitute another critical management component. These plans must comprehensively address equipment power isolation, personnel evacuation route design, and the operation of firefighting facilities, with regulatory standards requiring full coverage of these elements.

Furthermore, the adoption of advanced information management systems for real-time monitoring and data sharing of fire-related information has become a key measure for strengthening fire safety management. As recommended by the *Technical Specifications for Intelligent Fire Management*, records of fire drills and incidents should be systematically stored to facilitate data access and sharing. The application of systematic, data-driven fire management approaches has significantly enhanced fire prevention and control capability in power systems, ensuring stable and secure operation under high-risk conditions [30].

## CONCLUSION

In this study, a fire risk reliability assessment model for power distribution systems was established based on Risk-Based Inspection (RBI) technology. By defining and classifying the severity levels of fire accident consequences, the model enables a systematic evaluation of fire risks within distribution systems. A 330 kV

unmanned substation was selected as a representative case to demonstrate the practical applicability of the proposed model. Through detailed analysis of each functional zone within the substation, targeted fire prevention and mitigation measures were formulated.

The assessment results indicate that, across the four zones of the substation, there are 3 high-risk items, 6 medium-high-risk items, 14 medium-risk items, and 34 low-risk items. Based on these findings, the model effectively identifies critical components that require prioritized fire prevention and control actions. Overall, the proposed fire risk reliability model provides an accurate and efficient means of identifying fire hazards in power distribution systems, significantly reducing inspection workload and resource consumption while lowering maintenance costs and operational complexity.

## REFERENCES

- [1] Kumar, K. S., & Balachander, K. (2023). Fire risks in electrical installations: the review. In *E3S Web of Conferences* (Vol. 376, p. 01113). EDP Sciences.
- [2] Umar, A. S., & Hamid, Y. K. (2023). Summaries of Causes, Effects and Prevention of Solar Electric Fire Incidents. *International Journal of Engineering and Applied Physics*, 3(1), 663-672.
- [3] Chalishazar, V. H., Westman, J., Deines, J., Datta, S., Tagestad, J., Coleman, A., ... & Schaad, J. G. (2023, July). Wildfire risk evaluation framework for grid operations and planning. In *2023 IEEE Power & Energy Society General Meeting (PESGM)* (pp. 1-5). IEEE.
- [4] Bandara, S., Rajeev, P., & Gad, E. (2023). Power distribution system faults and wildfires: Mechanisms and prevention. *Forests*, 14(6), 1146.
- [5] Wu, J., Hu, Z., Chen, J., & Li, Z. (2018). Risk assessment of underground subway stations to fire disasters using Bayesian network. *Sustainability*, 10(10), 3810.
- [6] Kodur, V., Kumar, P., & Rafi, M. M. (2020). Fire hazard in buildings: review, assessment and strategies for improving fire safety. *PSU research review*, 4(1), 1-23.
- [7] Li, S., & Li, J. (2017). Condition monitoring and diagnosis of power equipment: review and prospective. *High Voltage*, 2(2), 82-91.
- [8] Zou, Q., Zhang, T., & Liu, W. (2021). A fire risk assessment method based on the combination of quantified safety checklist and structure entropy weight for shopping malls. *Proceedings of the Institution of Mechanical Engineers, Part O: Journal of Risk and Reliability*, 235(4), 610-626.
- [9] Muhammad, H., Jenuwa, N., & Jaafar, A. S. (2023). Fire safety system at cinema in Klang Valley. In *e-Proceeding of 6th Undergraduate Seminar on Built Environment and Technology (USBET) 2023* (pp. 864-873).
- [10] Wang, Y., Chen, G., Yang, F., Luo, Z., Yuan, B., Chen, X., & Wang, L. (2022). Serendipity discovery of fire early warning function of chitosan film. *Carbohydrate polymers*, 277, 118884.
- [11] Xu, H., Li, Y., Huang, N. J., Yu, Z. R., Wang, P. H., Zhang, Z. H., ... & Tang, L. C. (2019). Temperature-triggered sensitive resistance transition of graphene oxide wide-ribbons wrapped sponge for fire ultrafast detecting and early warning. *Journal of hazardous materials*, 363, 286-294.
- [12] Li, X., Vázquez-López, A., Sánchez del Río Sáez, J., & Wang, D. Y. (2022). Recent advances on early-stage fire-warning systems: mechanism, performance, and perspective. *Nano-micro letters*, 14(1), 197.

- [13] Dian, S., Cheng, P., Ye, Q., Wu, J., Luo, R., Wang, C., ... & Gong, X. (2019). Integrating wildfires propagation prediction into early warning of electrical transmission line outages. *IEEE Access*, 7, 27586-27603.
- [14] Yu, L. (2023, January). Neural Network Technology for Electrical Fire Early Warning System. In *International Conference on Innovative Computing* (pp. 308-315). Singapore: Springer Nature Singapore.
- [15] Gashteroodkhani, O. A., Majidi, M., & Etezadi-Amoli, M. (2021). Fire hazard mitigation in distribution systems through high impedance fault detection. *Electric Power Systems Research*, 192, 106928.
- [16] Kim, T. H., Yoo, J. G., & Jeon, J. C. (2015). Quantitative Analysis on the Electrical Fire Preventive Effect of Safety Inspection for Electrical Facilities for General Use. *The Transactions of the Korean Institute of Electrical Engineers P*, 64(2), 45-49.
- [17] Rad, M. D., Magyari, M., Moldovan, L., Fotau, D., & Salasan, D. (2020). Aspects concerning the importance of inspection and maintenance of electrical equipment with type of protection flameproof enclosure and increased safety used in liquefied petroleum gas car filling station. *International Multidisciplinary Scientific GeoConference: SGEM*, 20(1.2), 657-663.
- [18] Yabefa, E. T., & Ainah, P. K. (2021, April). Inspection of residential electrical installations in Bayelsa state: a review. In *IOP Conference Series: Earth and Environmental Science* (Vol. 730, No. 1, p. 012010). IOP Publishing.
- [19] Ko, K. S., Hwang, D. H., Park, S. J., & Moon, G. G. (2018). Electrical fire prediction model study using machine learning. *The Journal of Korea Institute of Information, Electronics, and Communication Technology*, 11(6), 703-710.
- [20] Hu, Y. N. (2016). Research on the application of fault tree analysis for building fire safety of hotels. *Procedia Engineering*, 135, 524-530.
- [21] Zhao, M., & Barati, M. (2021). A real-time fault localization in power distribution grid for wildfire detection through deep convolutional neural networks. *IEEE Transactions on Industry Applications*, 57(4), 4316-4326.
- [22] Ren, X., Li, C., Ma, X., Chen, F., Wang, H., Sharma, A., ... & Masud, M. (2021). Design of multi-information fusion based intelligent electrical fire detection system for green buildings. *Sustainability*, 13(6), 3405.
- [23] Emhemed, A. A., Fong, K., Fletcher, S., & Burt, G. M. (2016). Validation of fast and selective protection scheme for an LVDC distribution network. *IEEE Transactions on Power Delivery*, 32(3), 1432-1440.
- [24] Doshi, D. A., Khedkar, K., Raut, N., & Kharde, S. (2016). Real time fault failure detection in power distribution line using power line communication. *International Journal of Engineering Science*, 4834.
- [25] Le, V., Yao, X., Miller, C., & Tsao, B. H. (2020). Series DC arc fault detection based on ensemble machine learning. *IEEE Transactions on Power Electronics*, 35(8), 7826-7839.
- [26] Kumar, B. P., Ilango, G. S., Reddy, M. J. B., & Chilakapati, N. (2017). Online fault detection and diagnosis in photovoltaic systems using wavelet packets. *IEEE Journal of Photovoltaics*, 8(1), 257-265.
- [27] Lu, S., Phung, B. T., & Zhang, D. (2018). A comprehensive review on DC arc faults and their diagnosis methods in photovoltaic systems. *Renewable and Sustainable Energy Reviews*, 89, 88-98.

- [28] Arena Edoardo, Fargione Giovanna, Giudice Fabio & Latona Elisa. (2022). RBI-IOWs integrated approach to risk assessment: Methodological framework and application. *Journal of Loss Prevention in the Process Industries*, 79,
- [29] Stefan Veit & Frantisek Steiner. (2024). Defect Trends in Fire Alarm Systems: A Basis for Risk-Based Inspection (RBI) Approaches. *Safety*, 10(4), 95- 95.
- [30] Jiaqing Zhang, Yubiao Huang, Xinjie Qiu & Taiyun Zhu. (2022). A Review on Fire Research of Electric Power Grids of China: State-Of-The-Art and New Insights. *Fire Technology*, 60(2), 1027-1076.

A. M. Affif, Faculty of Architecture, Building, and Planning, The University of Melbourne, Parkville, 3010, Australia

Alan March, Faculty of Architecture, Building, and Planning, The University of Melbourne, Parkville, 3010, Australia

Yulesta Putra, Faculty of Architecture, Building, and Planning, The University of Melbourne, Parkville, 3010, Australia

Manuscript Published; 08 February 2025.